



17610_ins_wireless_temp_xmtr

Wireless Room Temperature Transmitter (Units without Humidity Sensing, Temperature Setpoint or Override)

Installation and Operating Instructions

rev. 04/21/15

Wireless Temperature Transmitter Overview and Identification

The BAPI Wireless Temperature Transmitter measures the room temperature and transmits the data at 418MHz or 433MHz RF to a receiver. The transmitter is mounted in a BAPI-Stat 2 style enclosure and has maximum in-building range of open-air range of 100 feet.

The transmit rate is approximately once every 20 seconds with an estimated battery life of 5 to 8 years using two high-capacity 3.6V lithium batteries. Each transmitter has a unique address with built-in error detection. Each variable sent by the transmitter is picked up by the receiver and converted by a separate BAPI Analog Output Module to a voltage, current or resistance signal which is sent to the controller.

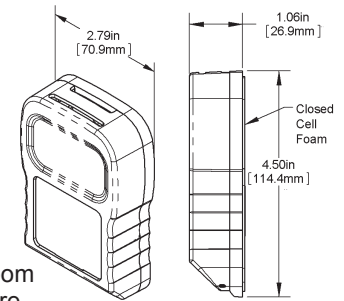

Fig. 1:
Wireless Room
Temperature
Transmitter

Complete Wireless Temperature and/or Humidity System Overview

418 MHz System:

The Transmitter measures the temperature or temp/humidity and transmits the data at 418MHz to the 418 MHz Receiver up to 100 feet away. The optional temperature setpoint and override status are also transmitted at 418 MHz to the receiver. The transmit rate is about once every 20 seconds with an estimated battery life of 5 to 8 years.

The information sent by the Transmitter is picked up by the 418 MHz Receiver and passed along to the Analog Output Modules. Each transmitted variable (temperature, humidity, setpoint, etc.) is converted by a separate output module into an analog resistance, voltage, current or relay contact which is hard wired to the analog inputs of the BAS controller.

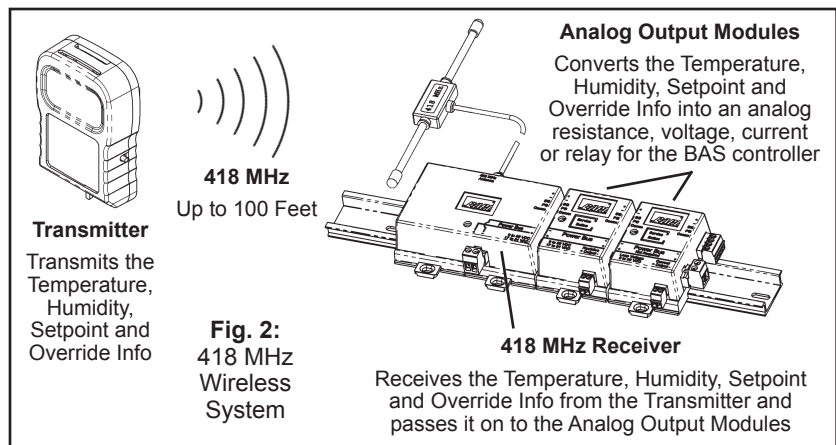

900 MHz System:

The Transmitter measures the room temperature or temp/humidity and transmits the data at 418MHz to a Repeater up to 100 feet away. The optional temperature setpoint and override status are also transmitted at 418 MHz to the Repeater. The transmit rate is approximately once every 20 seconds with an estimated battery life of 5 to 8 years.

The 418 MHz information sent by the Transmitter is picked up by the Repeater and then Re-Transmitted at 900 MHz to a 900 MHz Receiver up to 1,000 feet away. The 900 MHz receiver picks up the information from the repeater and then passes it along to the Analog Output Modules. Each transmitted variable (temperature, humidity, etc.) is converted by a separate output module into an analog resistance, voltage, current or relay contact which is hard wired to the analog inputs of the BAS controller.

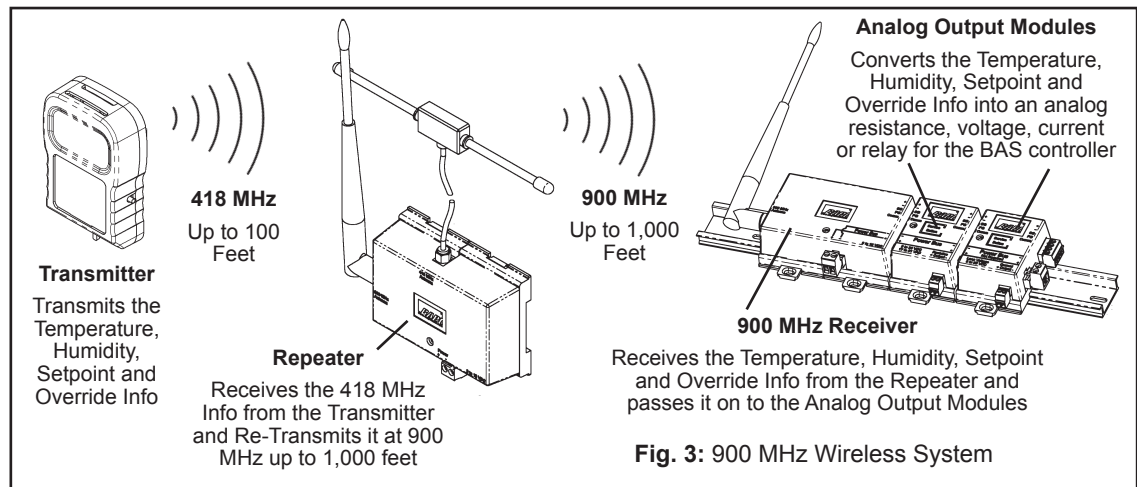

Customer Provided Tools and Materials

#2 Philips Screwdriver, 1/8" Screwdriver with 1/16" Allen wrench (BA/116W), Drill with 3/16" (4.7mm) bit

Specifications subject to change without notice.

Analog Output Module Training

The installation process requires that each transmitter is trained to its associated output module so that they communicate with each other. Pushing buttons in a defined sequence on the units will bind them together.

The training process is easiest on a test bench with the units within arm's reach of each other. Training can be done in the field but requires two people and a set of walkie talkies or cell phones. Be sure to place an identification mark on the transmitter and associated output module after they have been trained so that they can be matched together at the job site.

Perform the training sequence for each output module. Any transmitted variable can be trained to more than one output module. If a Repeater is used in the system, be sure it is powered and within reception range of the transmitter and the 900 MHz Receiver to train the output modules.

TEMPERATURE VARIABLE TRAINING

- To train an output module to a temperature variable, select the Resistance, Voltage or Current Output Module calibrated to the proper temperature range and connect it to the wireless receiver. Note: Multiple output modules can be trained to the same transmitter.
- Apply power to the receiver which will supply power to the connected output modules. The power LED on the receiver will light and remain lit. **(Current Output Modules must have loop power supplied to the module itself before they can be trained.)**
- Remove the cover of the room transmitter and remove the battery tabs or install the batteries, observing polarity as shown in Fig 4. The "transmit LED" will flash about once every 20 seconds, indicating a transmission.
- Press and hold down the "Service Button" on the top of the output module (Fig 5) that you wish to train. Then, press and release the "training button" (see Fig 4) on the transmitter. When the output module receives the "training transmission" from the transmitter, the output module's red LED will light steady. Release the "Service Button" on the output module and the red LED will go out. The transmitter and output module are now trained to each other. During normal operation, the output module's LED will flash about once every 20 seconds indicating data reception from the transmitter trained to it.
- Mount the transmitter at the desired location, removing the batteries if needed. (The units will remain trained through power failures and battery replacement.)

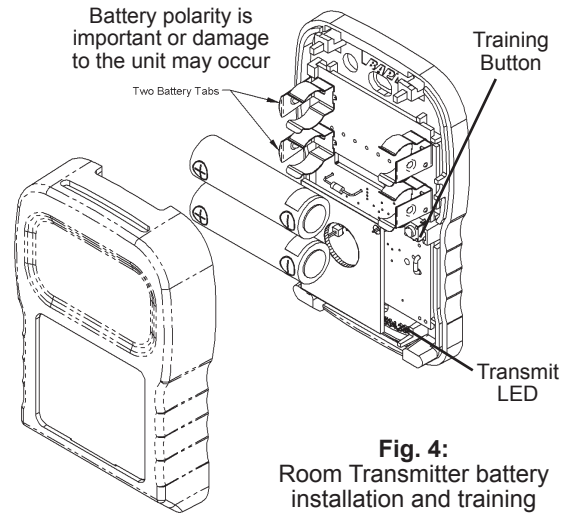

Fig. 4:
Room Transmitter battery installation and training

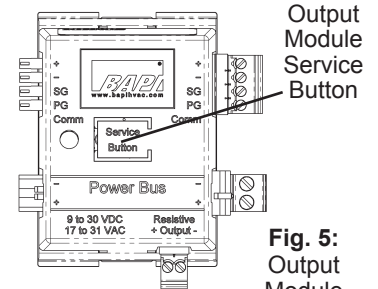

Fig. 5:
Output Module

Mounting of the Room Transmitter

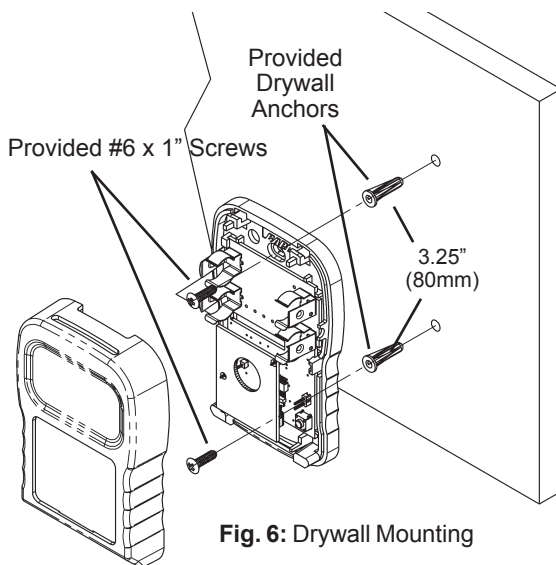

Fig. 6: Drywall Mounting

Note: The transmitter should have been trained to the output module at this point of the installation.

Drywall Mounting

- Place the base plate against the wall where you want to mount the sensor. Typically 5 feet above the floor.
- Using a pencil, mark out the two mounting holes.
- Drill two 3/16" (4.7 mm) holes in the center of each marked mounting hole. Insert a drywall anchor into each hole.
- Secure the base to the drywall anchors using the #6 x 1 inch mounting screws provided.
- Install provided batteries or pull battery tabs and follow polarity as shown in figure 3 or damage may occur. The unit will work on just one battery however the battery life will be cut in half.
- Attach cover by latching it to the top of the base, rotating the cover down and snapping it into place.
- Secure the cover by backing out the lock-down screws using a 1/16" Allen wrench until they are flush with the bottom of the cover.



Mounting of the 418 MHz Receiver, 900 MHz Receiver and Analog Output Modules

The 418 MHz Receiver, 900 MHz Receiver and Analog Output Modules can be mounted in snap track, DIN Rail or surface mounted. The text and figures refer to the 418 MHz Receiver, but the mounting process is the same for both receivers.

SNAPTRACK MOUNTING

Push in the blue mounting tabs on the bottom of the receiver and output modules. These units will now fit into the board slots of 2.75" snap track. Insert the receiver at the far left of the snap track, then insert each analog output module and slide it to the left until its connectors are fully mated into the receiver or the next analog output module. You may attach up to 127 analog output modules to a receiver.

If your output modules cannot fit in one piece of snap track, then mount another piece of snap track nearby and insert the additional modules. Connect wires from the right side of the first string of modules to the left side of the second string of modules on the second snap track. (See "Extending the RS485 Network" on pg. 5.) This configuration requires one or more Pluggable Terminal Block Connector Kits (BA/AOM-CONN).

DIN RAIL MOUNTING

Push out the blue mounting tabs on the bottom of the receiver and output modules. These units will now snap onto DIN Rail. Catch the EZ mount hook on the edge of the DIN rail as shown in Fig 9. Then rotate into place.

Attach the receiver at the far left of the DIN Rail, then attach each analog output module and slide it to the left until its connectors are fully mated into the receiver or the next analog output module. You may attach up to 127 analog output modules to a receiver.

If your output modules cannot fit onto one piece of DIN Rail, then mount another piece nearby and attach your additional modules. Connect wires from the right side of the first string of modules to the left side of the second string of modules on the second DIN Rail. (See "Extending the RS485 Network..." on pg. 5.) This configuration requires one or more Pluggable Terminal Block Connector Kits (BA/AOM-CONN).

SURFACE MOUNTING

Push out the blue mounting tabs on the bottom of the receiver and output modules. Attach the receiver to the surface by inserting a screw in each blue tab. Attach Analog Output Modules by placing each one against the surface and sliding it to the left until its connectors are fully mated into the receiver or the next analog output module. Attach each module to the surface with two screws, one in each blue tab. You may attach up to 127 analog output modules to a receiver.

If your output modules cannot fit in one straight line on the surface, then mount a second string of modules nearby. Connect wires from the right side of the first string of modules to the left side of the second string of modules. (See "Extending the RS485 Network..." on pg. 5.) This configuration requires one or more Pluggable Terminal Block Connector Kits (BA/AOM-CONN).

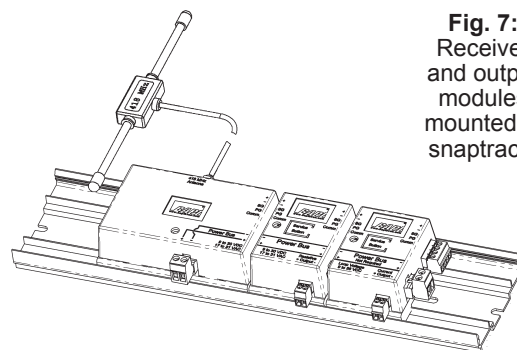

Fig. 7:
Receiver and output modules mounted in snaptrack.

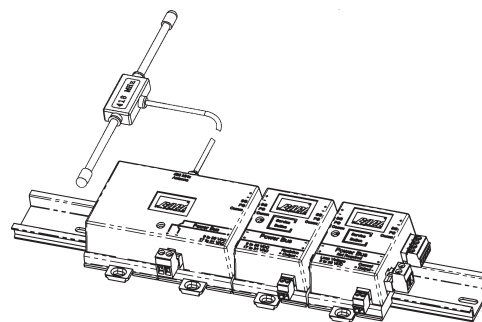

Fig. 8:
Receiver & output modules mounted on DIN Rail.

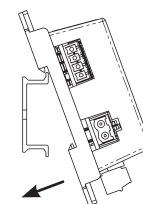

Fig. 9:
Catch the EZ Mount hook on the edge of the DIN Rail, then rotate into place.

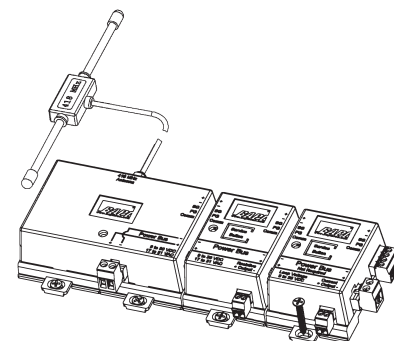

Fig. 10: Receiver and output modules surface mounted.

Wireless Temperature Transmitter Specifications

Supply Power: Two AA 3.6V Lith. batteries, 2.25 AH
5 to 8 year battery life at 20 second transmit rate

Temperature Input: Thermistor

Accuracy: $\pm 0.54^{\circ}\text{F}$ ($\pm 0.3^{\circ}\text{C}$)

Transmitted Range: -40 to 185°F (-40 to 85°C)

Antenna: Built inside the enclosure

Dimensions: Shown at the bottom of page 1

Environmental Operation Range:

Temp: 32° to 140°F (0° to 60°C)

Humidity: 5% to 95% RH non-condensing

Enclosure Material & Rating: ABS Plastic, UL94 V-0

Radio Frequency: 418 MHz North America

Transmitter Interval: ~20 seconds

FCC Approval #:

T4F061213RSO (418MHz Room Transmitter Only)

T4F060811TEMP (418MHz Temperature Probe Only)

T4F060811RH (418MHz Temp & Humidity Probe Only)

OUR9XSTREAM (Repeater Unit Only)

Compliance: This device complies with Part 15 of the FCC rules
Operation is subject to the following conditions.

1. This device may not cause harmful interference.
2. This device must accept any interference received, including interference that may cause undesired operation.

FCC Radio Frequency Interference Statement:

This equipment has been tested and found to comply with the limits for a Class B digital device, pursuant to Part 15, Subpart B, of the FCC Rules. This equipment generates, uses, and can radiate radio frequency energy. If not installed and used in accordance with the instructions, it may cause interference to radio communications.

418 MHz Receiver and 900 MHz Receiver with Analog Output Modules Termination

418 MHz System

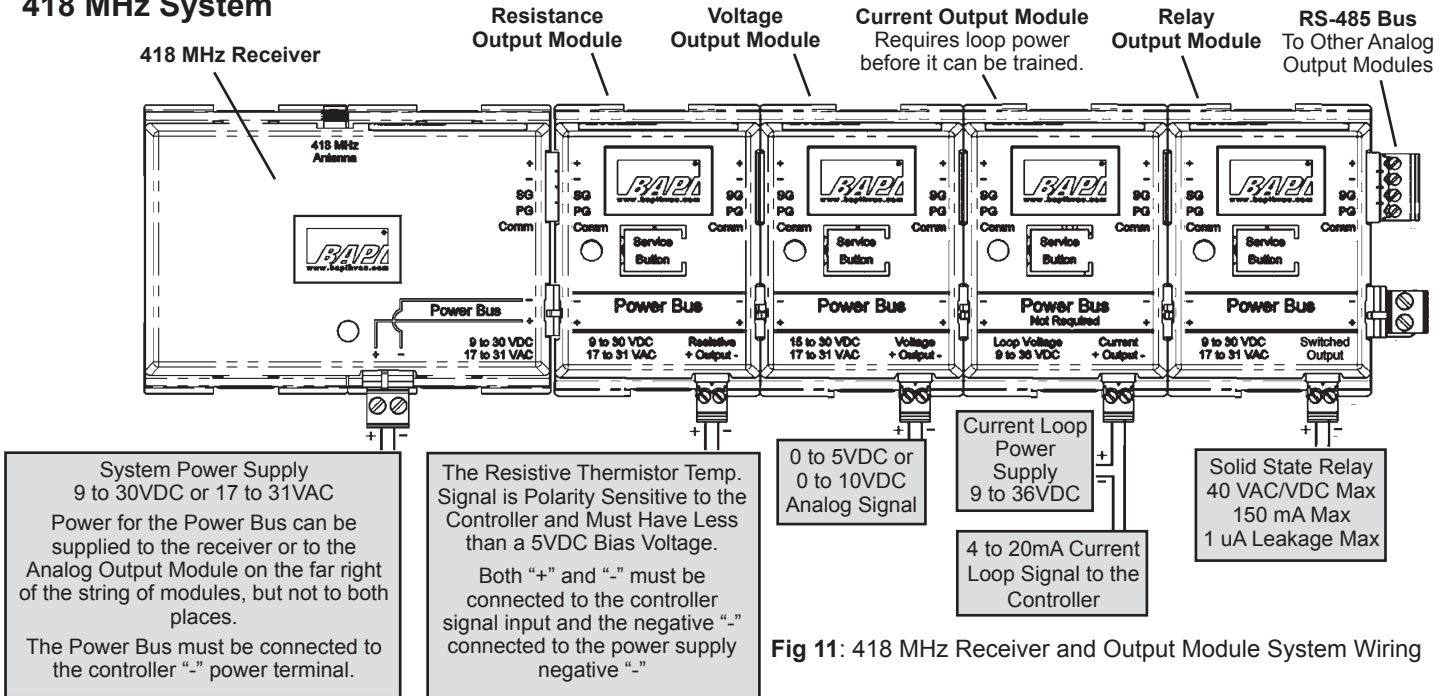

Fig 11: 418 MHz Receiver and Output Module System Wiring

Termination Notes for 418 MHz and 900 MHz Systems:

1. The wireless receiver and Analog Output Modules are interconnected and require module power along the "Power Bus" terminals. The bus can be powered from either the receiver end on the left or the last output module on the right side. Be sure you have enough DC current or AC VA for all the devices on the bus.
2. The **Current Output Module (BA/COM)** signal is **LOOP POWERED** and must be externally powered with 9 to 36 VDC separate from the Power Bus. The Loop Power must be connected to the Current Output Module before it can be trained.
3. Be sure to follow the polarity (+ or -) symbols listed on each receiver and the output modules to maintain communication and Power Bus integrity.

900 MHz System

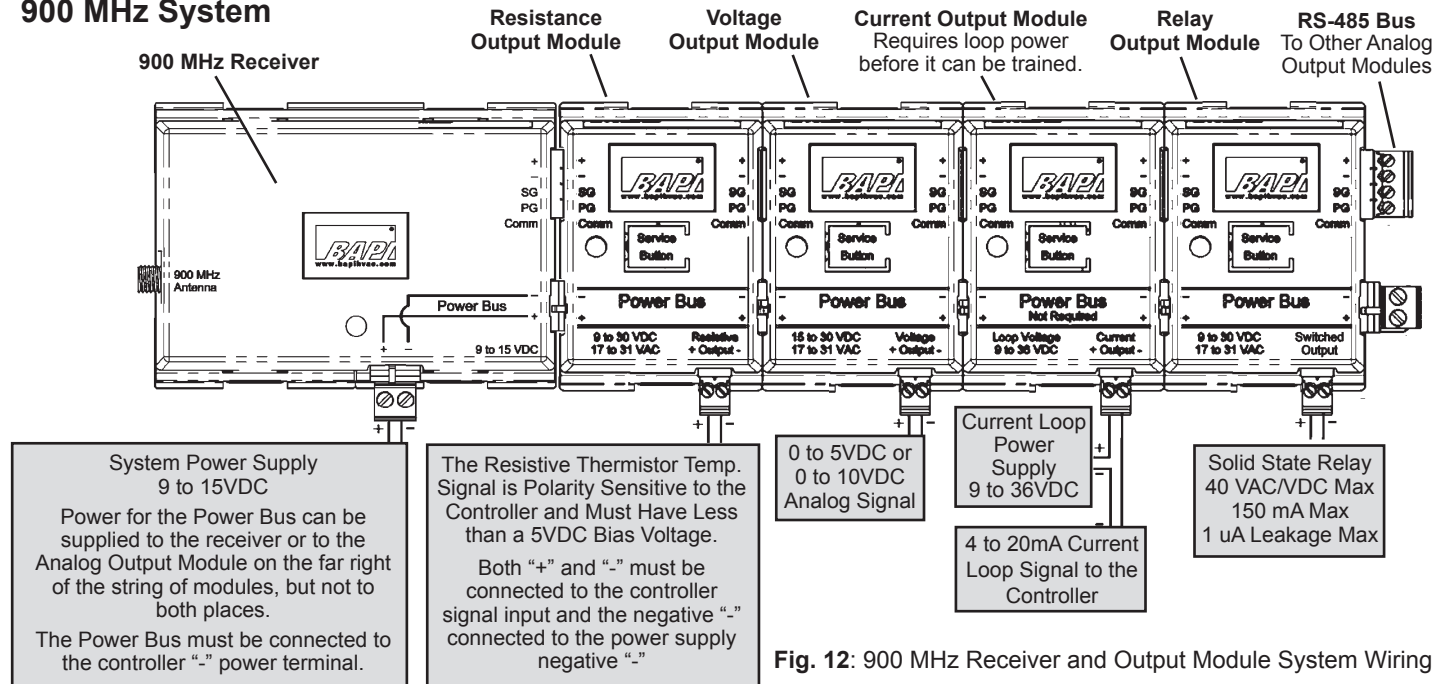

Fig 12: 900 MHz Receiver and Output Module System Wiring

Specifications subject to change without notice.

Extending the RS485 Network between the Receiver and the Analog Output Modules

The Analog Output Modules may be mounted up to 4,000 feet away from the receiver. The total length of all the shielded, twisted pair (TSP) cables shown in Fig 13 is 4,000 feet (1,220 meters). Connect the terminals together as shown in Fig 13. If the distance from the receiver to the group of Analog Output Modules is greater than 100 feet (30 meters), provide a separate power supply for that group of Output Modules. BAPI's VC350A-EZ Voltage Conv. and a small transformer are a perfect solution.

Note: This configuration requires one or more Pluggable Terminal Block Kits for the extra wire terminations on the left and right side of the Output Modules. Each kit includes 4 connectors.

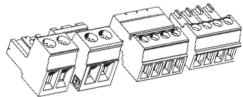

Pluggable Terminal Block Kit (BA/AOM-CONN)

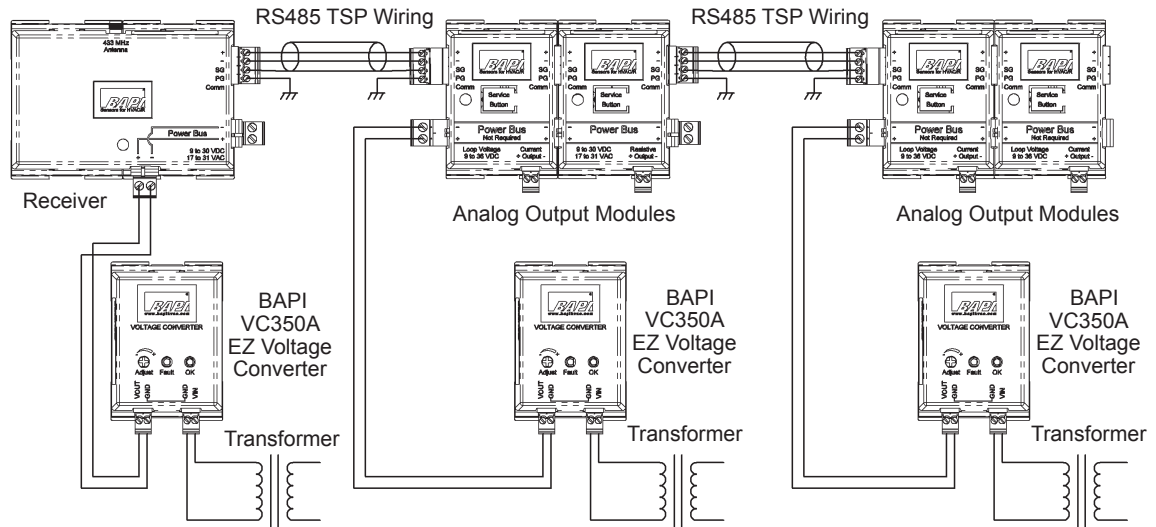

Fig. 13: Extended RS485 Network between the Receiver and the Analog Output Modules

Wireless System Diagnostics

Possible Problems:

Temperature or Humidity is reading its low limit or high limit, or the LED at the top of the Analog Output Module is blinking rapidly:

Temperature or Humidity reading is coming out the wrong output module

Temperature or Humidity reading is incorrect

Possible Solutions:

- Check for proper wiring and connections from the output modules to the controller.
- Check to see if the controller's software is configured properly.
- Check for proper power to the receiver, repeater (if used) and output modules.
- Retrain the Analog Output Module.
- Check that the associated transmitter is transmitting (the LED will flash about once every 20 seconds when it transmits). If not, replace the batteries. Check that the associated receiver is receiving the transmissions (its LED will blink right after the transmitter LED if it receives that transmission.) If it is not receiving the transmissions, move it closer to the transmitter or reposition the antenna for maximum reception.
- Note:** The receiver will receive transmissions from all transmitters that are within range, not just the one you are testing.
- Retrain the Analog Output Module.
- Check for proper wiring and connections from the output modules to the controller.
- Check to see if the controller's software is configured properly.
- Check to see if the correct output module is connected to the correct controller.

Analog Output Module Default Status when Wireless Transmission is Interrupted:

If an output module does not receive data from its assigned transmitter for 15 minutes, the red LED on the top of the module will blink rapidly. If this happens, the individual Analog Output Modules will react as follows:

- Resistance Output Modules (BA/ROM) calibrated for temperature will output the highest resistance in their output range.
- Voltage Output Modules (BA/VOM) calibrated for temperature will set their output to 0 volts.
- Current Output Modules (BA/COM) calibrated for temperature will set their output to 4 mA.
- Voltage Output Modules (BA/VOM) calibrated for humidity will set their output to their highest voltage (5 or 10 volts).
- Current Output Modules (BA/COM) calibrated for humidity will set their output to 20 mA.
- Setpoint Output Modules (BA/SOM) will hold their last value indefinitely.
- Relay Output Modules (BA/RyOM Units Only) will go to their default state (example: open for a normally open unit).

When a transmission is received, the output modules will revert to normal operation in 60 seconds or less.